

4

3

2

1

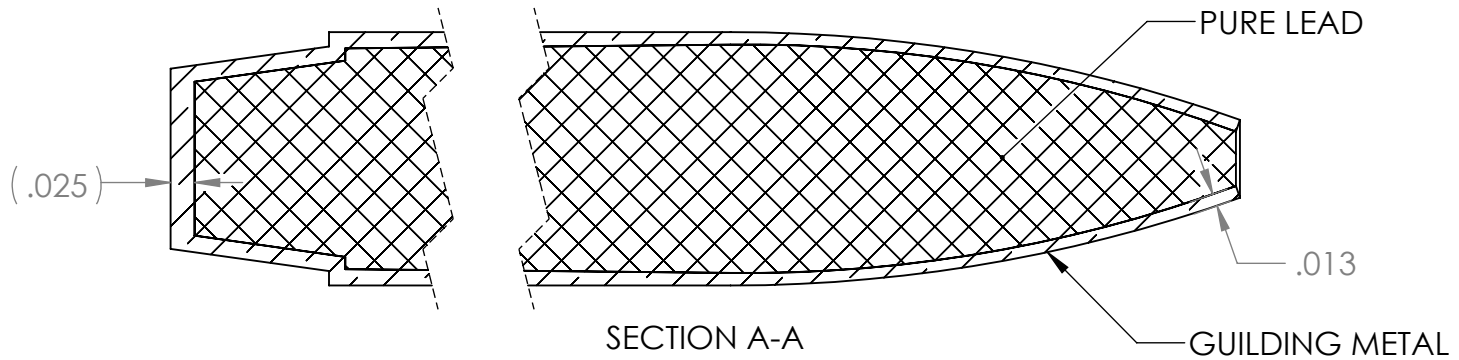
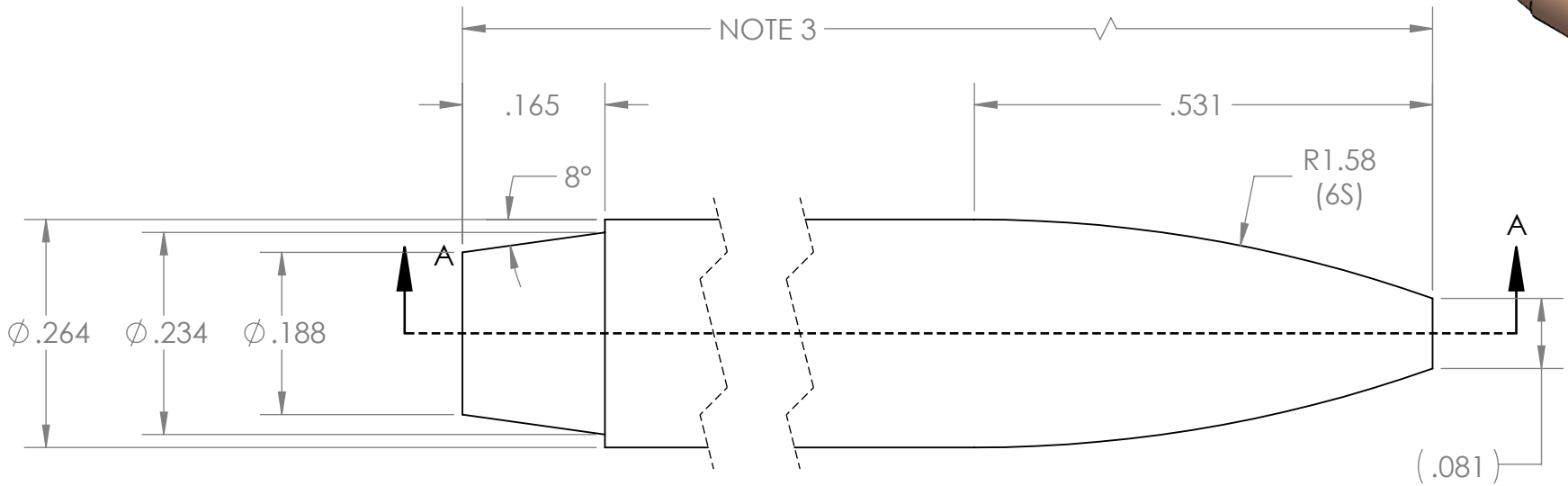
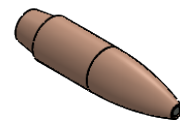

NOTES:

- JACKET MATERIAL: GUILDING METAL
- CORE MATERIAL: 99.9% PURE LEAD
- OVERALL LENGTH IS DEPENDENT ON DESIRED GRAIN WEIGHT. JACKET LENGTH AND LEAD CORE WEIGHT MUST BE DISCOVERED.

UNLESS OTHERWISE SPECIFIED:

DIMENSIONS ARE IN INCHES TOLERANCES:
 FRACTIONAL ± 1/2 DEGREE
 ANGULAR: MACH ± 1 BEND ± 1
 TWO PLACE DECIMAL ± .010
 THREE PLACE DECIMAL ± .005
 FOUR PLACE DECIMAL ± .0005
 SURFACE FINISH = $\sqrt{32}$ OR BETTER

PROPRIETARY AND CONFIDENTIAL

THE INFORMATION CONTAINED IN THIS DRAWING IS THE SOLE PROPERTY OF CORBIN MFG & SUPPLY, INC. ANY REPRODUCTION IN PART OR AS A WHOLE WITHOUT THE WRITTEN PERMISSION OF CORBIN MFG & SUPPLY, INC IS PROHIBITED.

	NAME	DATE
DRAWN		
CHECKED		
ENG APPR.		
MFG APPR.		
Q.A.		

COMMENTS:

CORBIN MFG & SUPPLY, INC.

TITLE:
CORBIN .264 CALIBER RB STANDARD

SIZE	DWG. NO.	REV
A	RBTO-4-S-264-6S	0

SCALE: 5:1	WEIGHT:	SHEET 1 OF 1
------------	---------	--------------

4

3

2

1

D

D

C

C

B

B

A

A